

LOAD RATINGS

RATING	Lbf	Newton
RADIAL BASIC DYNAMIC	3,930	17,481
MAXIMUM STATIC CAPACITY	8,500	37,808

NOTES:

- BEARING COMES PACKED WITH CARTER STANDARD FOOD GRADE H1, NLGI 2 GREASE

MS NO.

NSN NO.

DRAWING NO.

XDY-40-S

SIGNED DRAWING APPROVAL REQUIRED

PLEASE REVIEW AND VERIFY INFORMATION ON ALL SHEETS & RETURN COPY WITH SIGNED AND DATED APPROVAL, AND/OR REQUIRED CHANGES. CARTER WILL NOT PROCEED WITH ORDER UNTIL APPROVAL IS RECEIVED

SIGNED _____

DATE _____

APPROVED

REJECTED

ISO VIEW
SCALE 1.500 : 1

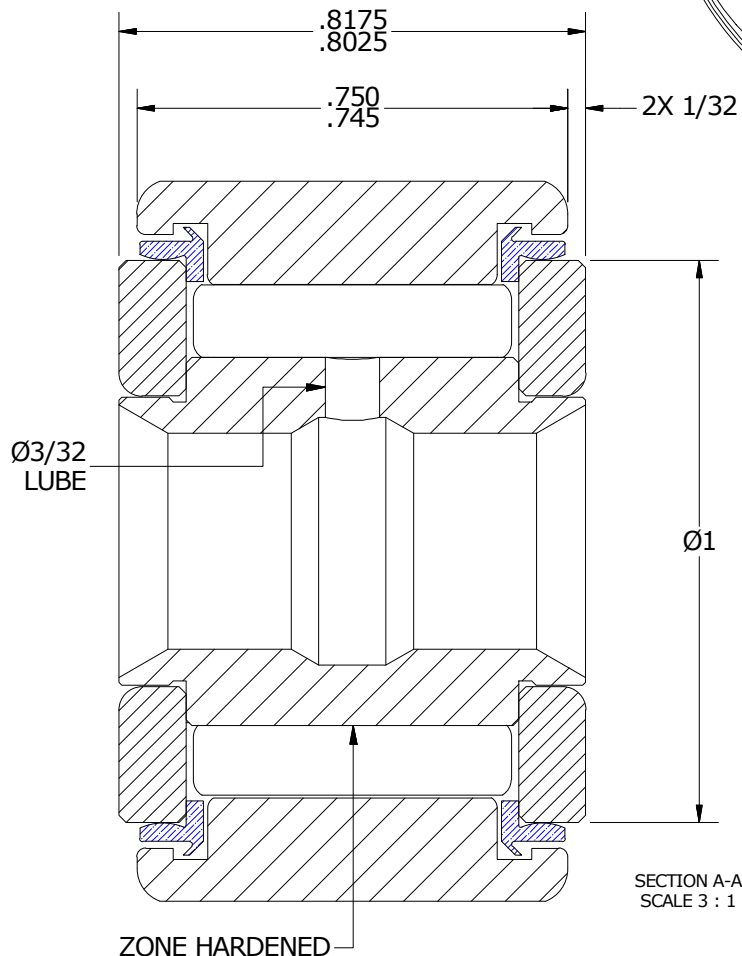
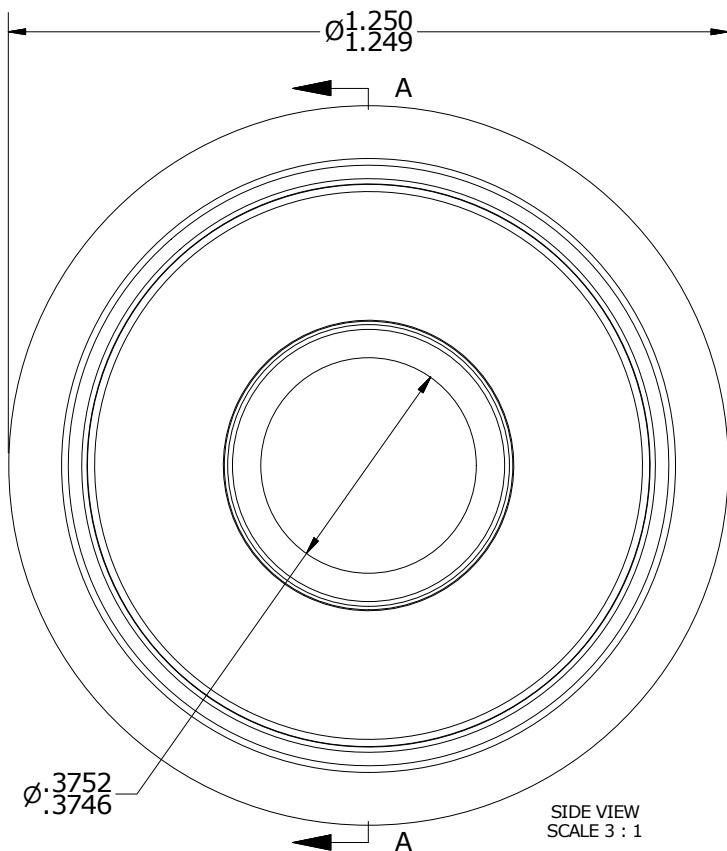
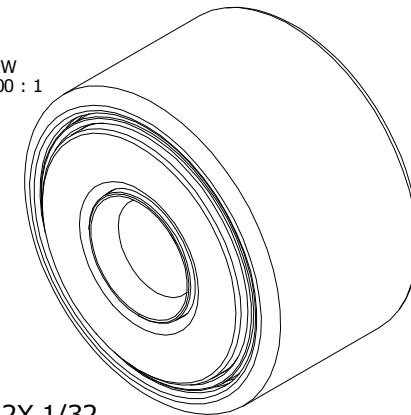

MATERIAL NOTES:

OUTER RING - XD15NW STAINLESS STEEL, HEAT TREATED
 INNER RING - XD15NW STAINLESS STEEL, ZONE HARDENED
 NEEDLE ROLLER(S) - XD15NW STAINLESS STEEL, HEAT TREATED
 WASHER(S) - XD15NW STAINLESS STEEL, HEAT TREATED
 SEAL(S) - SYNTHETIC

CUSTOMER PART#

XX = ± .01
 XXX = ± .005
 XXXX = ± .0005
 ANGLES = ± 1'
 INCH [METRIC]
 FRACTION = ± 1/32

CARTER MANUFACTURING IS NOT RESPONSIBLE FOR TYPOGRAPHICAL ERRORS

CARTER MANUFACTURING CO., INC.

GRAND HAVEN, MICHIGAN 49417

ENGINEERING CHANGE ORDER NOTE

REVISION

PART NAME: ASSEMBLY

PRODUCT TYPE: XDY

A

AUTHOR BY
HG

DRAWN BY
SGW

CHK'D BY
MD

SALES
KR

MATERIAL
NOTED

REVISION BY
SGW

DATE
5/21/2018

DATE
4/6/2018

DATE
5/17/2018

DATE
5/17/2018

SHEET
1 OF 2